



Charles Darwin University

Photonic-assisted one-third microwave frequency divider

Zhang, Yu; Zheng, Ruiqi; Chan, Erwin Hoi Wing; Wang, Xudong; Feng, Xinhuan; Guan, Bai Ou; Yao, Jianping

Published in:
Electronics Letters

DOI:
[10.1049/ell2.12542](https://doi.org/10.1049/ell2.12542)

Published: 01/08/2022

Document Version
E-pub ahead of print

[Link to publication](#)

Citation for published version (APA):

Zhang, Y., Zheng, R., Chan, E. H. W., Wang, X., Feng, X., Guan, B. O., & Yao, J. (2022). Photonic-assisted one-third microwave frequency divider. *Electronics Letters*, 58(16), 627-629. <https://doi.org/10.1049/ell2.12542>

General rights

Copyright and moral rights for the publications made accessible in the public portal are retained by the authors and/or other copyright owners and it is a condition of accessing publications that users recognise and abide by the legal requirements associated with these rights.

- Users may download and print one copy of any publication from the public portal for the purpose of private study or research.
- You may not further distribute the material or use it for any profit-making activity or commercial gain
- You may freely distribute the URL identifying the publication in the public portal

Take down policy

If you believe that this document breaches copyright please contact us providing details, and we will remove access to the work immediately and investigate your claim.

Photonic-assisted one-third microwave frequency divider

Yu Zhang,¹ Ruiqi Zheng,¹ Erwin Hoi Wing Chan,^{2,✉}
Xudong Wang,^{1,✉} Xinhuan Feng,¹ Bai-Ou Guan,¹
and Jianping Yao^{1,3}

¹Guangdong Provincial Key Laboratory of Optical Fiber Sensing and Communications, Institute of Photonics Technology, Jinan University, Guangzhou, China

²College of Engineering, IT and Environment, Charles Darwin University, Darwin, Northern Territory, Australia

³Microwave Photonics Research Laboratory, School of Electrical Engineering and Computer Science, University of Ottawa, Ottawa, Canada

✉ Email: txudong.wang@email.jnu.edu.cn; erwin.chan@cdu.edu.au

A microwave photonic frequency divider to produce a frequency-divided microwave signal with its frequency that is one-third the frequency of the input microwave signal is proposed and experimentally demonstrated. The key novelty of the approach is that the phase control, a condition to realise the frequency division operation, is implemented through controlling the modulator bias voltage, enabling a wideband, high resolution and fast response phase control. One-third frequency division with an ultra-high harmonic suppression of over 71.5 dB is demonstrated for the first time.

Introduction: A microwave frequency divider is a device that takes a microwave signal with a frequency f_{RF} and produces an output signal with a frequency f_{RF}/N , where N is an integer. It is an important component for applications in communications systems and instruments. For example, using a one-third frequency divider followed by a frequency doubler or quadrupler in a communication system can guarantee that neither the LO nor any of its harmonics has a frequency corresponding to that of the received or transmitted signal, avoiding the LO signal to interact with the received or transmitted signal, which would degrade the system performance [1]. Implementing frequency division in the optical domain can overcome the limited operating frequency range of electronic frequency dividers. In addition, it also has other advantages such as low loss, light weight, and high reconfigurability. Several photonics-based microwave frequency divider structures have recently been reported. Most of them use an optoelectronic oscillator (OEO) to realise frequency division through injection locking [2, 3] or based on regenerative technique [4–7]. Both techniques require a precise control of the gain and phase, a condition needed for frequency division at a given input frequency. For example, the phase condition requires that a frequency-divided signal traveling in one round trip of an OEO loop to have a phase shift that is an integer times of 2π . Until now, most photonic-assisted microwave frequency dividers implemented based on an OEO use either an electrical phase shifter (EPS) or an optical variable delay line (OVDL) to control the round-trip signal phase, which may make the bandwidth, phase shift range and resolution limited. In addition, the phase tuning speed is also low.

In this paper, we present a new approach to implement a one-third microwave frequency divider without the need to control the phase using an EPS or an OVDL. The key novelty of the approach is that the phase condition required to realise the frequency division operation is implemented through controlling the modulator bias voltage, enabling a wideband, high resolution and fast response phase control. Experimental results show that one-third frequency division with an ultra-high harmonic suppression of over 71.5 dB is achieved. Thanks to the frequency division, the phase noise performance has been improved by around 9 dB.

Structure and operation principle: Figure 1 shows the schematic diagram of the proposed photonic microwave frequency divider. It consists of a laser source, a dual-parallel Mach-Zehnder modulator (DPMZM), an optical bandpass filter (OBPF), and an OEO. A continuous wave (CW) light with an angular frequency ω_c generated by the laser source is sent to the DPMZM, which consists of two sub-MZMs (MZM1 and

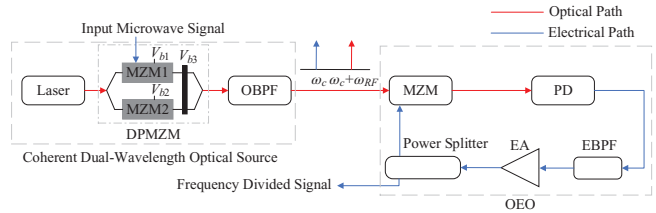

Fig. 1 Schematic diagram of the proposed one-third frequency divider. DPMZM: dual-parallel Mach-Zehnder modulator; OBPF: optical bandpass filter; MZM: Mach-Zehnder modulator; PD: photodetector; EA: electronic amplifier; EBPF: electrical bandpass filter

MZM2) on each arm of the main MZM. A microwave signal to be frequency divided is injected into MZM1 via the RF port. A DC bias voltage V_{b1} is applied to MZM1 via the DC port to bias MZM1 at the null point. Therefore, a pair of first-order sidebands are generated at the output of MZM1 with the carrier being suppressed. No microwave signal is applied to MZM2. Hence, only an optical carrier is present at the output of MZM2. The DC bias voltage V_{b2} applied to MZM2 is tuned such that the optical carrier at the output of MZM2 has the same amplitude as the first-order RF modulation sidebands generated by MZM1. The phase difference between the sideband and the optical carrier can be controlled by the DC bias voltage V_{b3} of the main MZM. The OBPF connected to the DPMZM output is used to filter out the lower sideband. This process produces a coherent dual-wavelength optical signal with a frequency separation equals to the input microwave signal frequency and a phase difference determined by the main MZM DC bias voltage V_{b3} .

The coherent dual-wavelength optical signal is launched into the OEO. The OEO loop consists of an MZM, a photodetector (PD), an electronic amplifier (EA), an electrical bandpass filter (EBPF), and a 3-dB power splitter. The structure is similar to a conventional OEO [8], but the MZM is biased at the null point. Once the round-trip gain of the one-third frequency component is unity and the round-trip phase of the one-third frequency component is an integer times of 2π [5], a new microwave signal with a frequency that is one-third the input microwave frequency is generated at the output of the OEO. This can be done by controlling the EA gain and the DC bias voltage of the main MZM in the DPMZM, which can be seen from the analysis given in the following section. It can be seen from Figure 1 that the frequency divider is implemented by a DPMZM and an MZM connected in series. To our knowledge, three microwave frequency dividers based on cascaded modulators have been reported [6, 7, 9], but all require using an EPS to control the round-trip phase for generating a frequency-divided signal.

Analysis: Considering a microwave signal with an angular frequency ω_{RF} into the DPMZM shown in Figure 1, the DPMZM output electric field is given by

$$E_{DPMZM}(t) = \frac{1}{2} E_{in} \sqrt{t_{ff1}} e^{j\omega_c t} \left[-J_1(\beta_{RF}) e^{-j(\omega_{RF}t + \theta_{RF})} + J_1(\beta_{RF}) e^{j(\omega_{RF}t + \theta_{RF})} + \cos\left(\frac{\beta_{b2}}{2}\right) e^{j\left(\frac{\beta_{b2}}{2} + \beta_{b3}\right)} \right], \quad (1)$$

where E_{in} is the electric field amplitude of the CW light into the DPMZM, t_{ff1} is the DPMZM insertion loss, $J_n(x)$ is the Bessel function of the first kind of order n , $\beta_{RF} = \pi V_{RF}/V_{\pi,RF}$ is the modulation index, V_{RF} and θ_{RF} are the voltage and the phase of the microwave signal into MZM1, respectively, $V_{\pi,RF}$ is the modulator RF port switching voltage, $\beta_{bi} = \pi V_{bi}/V_{\pi,DC}$ is the bias angle introduced by the bias voltage V_{bi} , $i = 1, 2$, or 3 , and $V_{\pi,DC}$ is the modulator DC port switching voltage. As can be seen, the amplitude and phase of the optical carrier at the output of the DPMZM are dependent on V_{b2} and V_{b3} . Hence V_{b2} can be adjusted such that the carrier and the sidebands have the same amplitude, while a tunable phase difference between the carrier and the sideband can be obtained by adjusting V_{b3} . Since the lower RF modulation sideband is removed by the OBPF, the electric field of the coherent dual-wavelength optical signal into the OEO loop is the same as (1) with the first term inside the square brackets being eliminated.

Assuming a microwave signal generated by the OEO is given by

$$V_{osc}(t) = V_{osc} \sin(\omega_{osc}t + \theta_{osc}), \quad (2)$$

where V_{osc} , ω_{osc} and θ_{osc} are the amplitude, angular frequency, and phase of the microwave signal, respectively. As shown in Figure 1, this microwave signal is fed back into the null-biased MZM inside the OEO loop. The electric field of the optical signal after the MZM is given by

$$E_{out}(t) = \frac{1}{2} E_{in} \sqrt{t_{f1} t_{f2}} e^{j\omega_c t} \times \left[J_1(\beta_{RF}) e^{j(\omega_{RF}t + \theta_{RF})} + \cos\left(\frac{\beta_{b2}}{2}\right) e^{j\left(\frac{\beta_{b2}}{2} + \beta_{b3}\right)} \right] \cdot J_1(\beta_{osc}) \left[e^{j(\omega_{osc}t + \theta_{osc})} - e^{-j(\omega_{osc}t + \theta_{osc})} \right] \quad (3)$$

where t_{fj} is the MZM insertion loss and $\beta_{osc} = \pi V_{osc}/V_{\pi,RF}$ is the modulation index. There are four optical frequency components, which can be seen by expanding (3), at the output of the MZM, with the angular frequencies $\omega_c \pm \omega_{osc}$ and $\omega_c + \omega_{RF} \pm \omega_{osc}$. The beating of these optical frequency components at the PD will generate a photocurrent that has angular frequencies of $2\omega_{osc}$, $\omega_{RF} \pm 2\omega_{osc}$ and ω_{RF} . The EBPF filters out the high frequency components leaving a low frequency component at $\omega_{RF} - 2\omega_{osc}$. The photocurrent after the EBPF becomes

$$I_{EBPF}(t) = -\frac{1}{2} t_{f1} t_{f2} P_{in} J_1^2(\beta_{osc}) J_1(\beta_{RF}) \cos\left(\frac{\beta_{b2}}{2}\right) \Re \cdot \cos\left((\omega_{RF} - 2\omega_{osc})t + \theta_{RF} - 2\theta_{osc} - \frac{\beta_{b2}}{2} - \beta_{b3}\right), \quad (4)$$

where P_{in} is the CW light power into the DPMZM and \Re is the responsivity of the PD. The photocurrent at $\omega_{RF} - 2\omega_{osc}$ is amplified by the EA and is split into two portions by the 3 dB power splitter. Half of this microwave signal leaves the OEO loop while the other half is fed back into the null-biased MZM. The microwave signal into the MZM can be written as

$$V_o(t) = -\frac{\sqrt{2}}{4} \sqrt{G_{EA} t_{f1} t_{f2} P_{in}} J_1^2(\beta_{osc}) J_1(\beta_{RF}) \cos\left(\frac{\beta_{b2}}{2}\right) \Re R_o \cdot \cos\left((\omega_{RF} - 2\omega_{osc})t + \theta_{RF} - 2\theta_{osc} - \frac{\beta_{b2}}{2} - \beta_{b3}\right), \quad (5)$$

where G_{EA} is the gain of the EA and R_o is the load resistance of the PD.

In order to obtain a stable oscillation, the OEO output signal needs to be equal to $V_{osc}(t)$. By equating (2) and (5), the OEO output signal frequency is one-third the frequency of the input microwave signal. The gain and the phase conditions for the OEO to generate a one-third microwave frequency can be obtained from (2) and (5), and are given by

$$V_{osc} = -\frac{\sqrt{2}}{4} \sqrt{G_{EA} t_{f1} t_{f2} P_{in}} J_1^2(\beta_{osc}) J_1(\beta_{RF}) \cos\left(\frac{\beta_{b2}}{2}\right) \Re R_o, \quad (6)$$

$$\theta_{RF} - 3\theta_{osc} - \frac{\beta_{b2}}{2} - \beta_{b3} + \frac{\omega_{RF}}{3} \tau = 2k\pi, \quad (7)$$

where τ is the time required for the microwave signal to travel in one round trip inside the OEO loop and k is an integer. The gain condition given in (6) can be satisfied by designing the EA gain G_{EA} . In addition to the EA, an optical amplifier can be incorporated into the loop between the MZM and the PD to control the OEO loop gain. The phase of the frequency divided microwave signal into the MZM is determined by the DPMZM bias voltages V_{b2} and V_{b3} . Since the amplitude of the optical carrier at the output of the DPMZM is also dependent on V_{b2} , V_{b2} is used to make the carrier to have the same amplitude as the sideband. Therefore, the main MZM bias voltage V_{b3} is used to control the round-trip phase of the frequency divided signal to satisfy the phase condition given in (7). This is different from the previously reported injection locking and regenerative photonic microwave frequency dividers [3–7], which use an EPS or an OVDL to control the round-trip signal phase to satisfy the phase condition. Using V_{b3} to control the microwave signal phase has a number of advantages over the conventional electrical approaches. First, it avoids using an electrical component that limits the

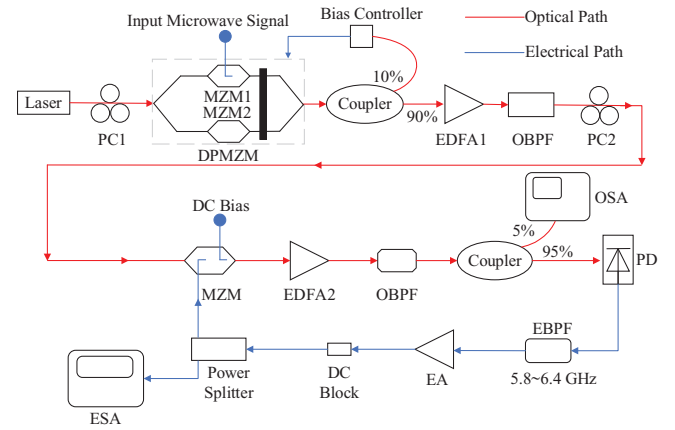

Fig. 2 Experimental setup of the one-third frequency divider. EDFA: erbium-doped fibre amplifier; ESA: electrical spectrum analyser; OSA: optical spectrum analyser

operating frequency range of the frequency divider. Second, a full and continuous 0–360° phase shift range can be obtained by controlling V_{b3} . On the other hand, although electrical digital phase shifters can provide 0° to 360° phase shift, they have a limited phase shift resolution. For example, an 8-bit phase shifter (Pasternack 8-bit programmable phase shifter PE82P5002) has a resolution of 1.406°. Hence not all microwave frequency can be divided when using a digital phase shifter in an injection locking or regenerative frequency divider. A continuous phase shift can be obtained by using electrical analogue phase shifters. However, they have a limited phase shift range. For example, a full 0–360° phase shift range can only be obtained for a microwave signal with a frequency of between 5 and 10 GHz in a 5–18 GHz analogue phase shifter (Analog Devices 400° analog phase shifter HMC247). Furthermore, the phase shifter insertion loss will change when tuning the phase shift, which will affect the gain condition. Hence, the gain of the amplifier inside the OEO loop needs to be readjusted as the input microwave signal frequency is tuned. Note that it is possible to use either an optical or an electrical variable delay line to control the signal round-trip delay time to satisfy the phase condition. However, frequency dividers implemented using a variable delay line has a slow response time because a change in the input microwave signal frequency requires readjustment of the variable delay line, which has a slow tuning speed.

Once the gain and phase conditions given in (6) and (7) are satisfied, a microwave signal with a frequency that is one-third the input microwave frequency is generated. Since an EBPF is employed inside the OEO loop, no harmonic components are present at the output of the frequency divider. The bandwidth of the proposed one-third frequency divider is determined by the bandwidth of the EBPF. Since the EBPF needs to pass the frequency component at $\omega_{RF}/3$ while suppressing the second and higher order harmonics, the frequency divider has a sub-octave operating frequency range and the frequency range of the input microwave signal can be three times the bandwidth of the EBPF.

Experiment: An experiment is performed based on the setup shown in Figure 2. The blue solid line in Figure 3 shows the optical spectrum measured at the 5% coupling ratio optical coupler output after properly adjusting the bias voltage V_{b3} of the main MZM in the DPMZM via the bias controller and the gain of EDFA2 inside the OEO loop. It can be seen there are four main frequency components. They are the sidebands at the frequencies of ± 6 GHz away from the dual-wavelength optical signal that has a frequency separation of 18 GHz. This agrees with the analysis discussed in the previous section. The coherent dual-wavelength optical signal is around 10 dB below the sidebands. The reason why the coherent dual-wavelength optical signal is not fully suppressed is because the MZM has a limited extinction ratio. Figure 3 also shows the optical spectrum at the input of the OEO loop. As can be seen, the power of the coherent dual-wavelength optical signal required to generate a frequency divided signal is around -20 dBm, which is determined by the power of the input microwave signal and the gain of EDFA1. For a given input microwave signal power, the gain of EDFA1 can be adjusted to

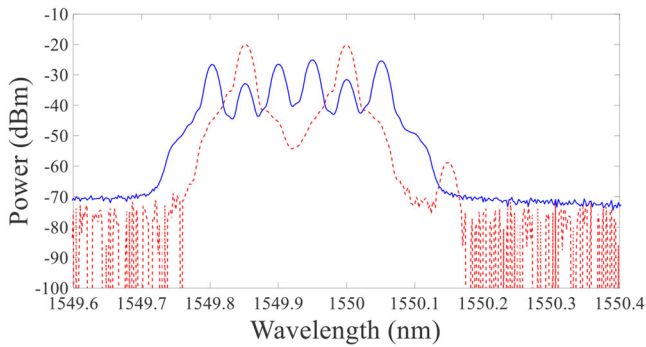

Fig. 3 Optical spectrum at the input (red dashed line) and output (blue solid line) of the OEO loop when an 18 GHz microwave signal is applied to the frequency divider

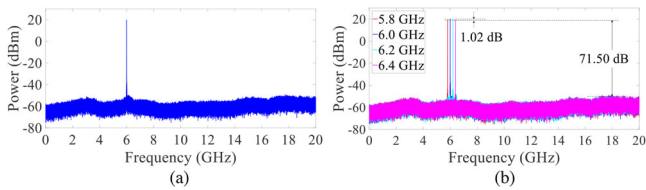

Fig. 4 Electrical spectrums at the output of the frequency divider for (a) an 18 GHz microwave signal and (b) different frequency microwave signals into the frequency divider

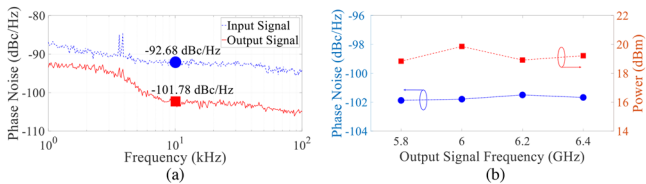

Fig. 5 (a) Phase noise spectrum of the input 18 GHz microwave signal (blue dashed line) and the frequency divided 6 GHz signal (red solid line). (b) Phase noise at a 10 kHz frequency offset and frequency divided signal power for different input microwave signal frequencies

ensure the power of the coherent dual-wavelength optical signal is around -20 dBm. Hence, the proposed one-third frequency divider has a wide input power dynamic range. Figure 4(a) shows the frequency divider output electrical spectrum. It can be seen that the frequency divider output only contains the one-third frequency component at 6 GHz. Figure 4(b) shows the output electrical spectrum of the frequency divider for different input microwave signal frequencies of 17.4 GHz, 18 GHz, 18.6 GHz and 19.2 GHz. Note that only the DPMZM bias voltage V_{b3} is adjusted as the input microwave signal frequency changed to obtain the one-third frequency component. The gain of EDFA2 remains unchanged. The frequency divider operating frequency range is limited by the bandwidth of the EBPF used in the experiment. A very high harmonic suppression ratio of over 71.5 dB can be seen in Figure 4(b). This is 50.2 dB and 35.4 dB higher than those reported in [4] and [6], respectively. Figure 4 shows that the system noise floor is around -55 dBm, which is measured using an ESA resolution bandwidth of 100 kHz and attenuation setting of 40 dB. The noise floor is generated by all noise components present in the system, which include the laser relative intensity noise (RIN), the signal spontaneous beat noise, the shot noise and the thermal noise.

The phase noise of the generated frequency-divided microwave signal is investigated. This is done by measuring the single-sideband phase noise using the ESA when an 18 GHz microwave signal is applied to the frequency divider. The phase noise spectrums of the input and output signals are shown in Figure 5(a). As can be seen, the phase noise of the one-third frequency divided microwave signal is -101.8 dBc/Hz at a 10 kHz frequency offset. This is a 9.1 dB improvement compared to the

input microwave signal phase noise of -92.7 dBc/Hz at a 10 kHz frequency offset. This matches well with the theoretical value of 9.5 dB calculated by $20 \cdot \log_{10}(M)$ where M is the multiplication factor. Figure 5(b) shows the phase noise and the power of the frequency divider output signal for the input microwave signal at different frequencies. It can be seen that the phase noise and the power of the frequency divider output signal is around -102 dBc/Hz and around 19.5 dBm, respectively. Figure 5(b) also shows the output microwave signal has less than 0.5 dB phase noise variation and around 1 dB power variation when a microwave signal with a frequency between 17.4 and 19.2 GHz into the frequency divider.

Conclusion: A photonic-assisted microwave frequency divider to perform one-third frequency division has been presented. The key contribution of the proposed approach is the use of a DPMZM, through tuning the bias voltage of the main MZM in the DPMZM, the phase condition required for one-third frequency division was achieved. This eliminates the use of either an EPS, which has a limited bandwidth and a limited phase shift range and resolution, or an OVDL, which has a slow phase tuning speed. The proposed frequency divider was analysed theoretically and demonstrated experimentally. The results showed that one-third frequency division over a frequency range from 17.4 to 19.2 GHz with an ultra-high harmonic suppression of over 71.5 dB was achieved.

Funding information: This work was supported in part by Guangdong Province Key Field R&D Program Project under Grant 2020B0101110002, in part by the National Natural Science Foundation of China under Grant 618620206002 and Grant 61771221, and in part by the National Key R&D Program of China under Grant 2021YFB2800804.

Data availability statement: The data that support the findings of this study are available from the corresponding author upon reasonable request.

© 2022 The Authors. *Electronics Letters* published by John Wiley & Sons Ltd on behalf of The Institution of Engineering and Technology.

This is an open access article under the terms of the Creative Commons Attribution License, which permits use, distribution and reproduction in any medium, provided the original work is properly cited.

Received: 18 March 2022 Accepted: 21 May 2022

doi: 10.1049/ell2.12542

References

- Magoon, R., Molnar, A.: RF local oscillator path for GSM direct conversion transceiver with true 50% duty cycle divide by three and active third harmonic cancellation. 2002 IEEE Radio Frequency Integrated Circuits (RFIC) Symposium, pp. 23–26. IEEE, Piscataway, NJ (2002)
- Xu, Y., Peng, H., Guo, R., et al.: Injection-locked millimeter wave frequency divider utilizing optoelectronic oscillator based optical frequency comb. *IEEE Photon. J.* **11**(3), 1–8 (2019)
- Meng, Y., Hao, T., Li, W., et al.: Microwave photonic injection locking frequency divider based on a tunable optoelectronic oscillator. *Opt. Express* **29**(2), 684–691 (2021)
- Liu, S., Lv, K., Fu, J., et al.: Wideband microwave frequency division based on an optoelectronic oscillator. *IEEE Photon. Technol. Lett.* **31**(5), 389–392 (2019)
- Duan, S., Mo, B., Wang, X., et al.: Photonic-assisted regenerative microwave frequency divider with a tunable division factor. *J. Lightwave Technol.* **38**(19), 5509–5516 (2020)
- Zhou, H., Liu, S., Kang, X., et al.: Broadband two-thirds photonic microwave frequency divider. *Electron. Lett.* **55**(21), 1141–1143 (2019)
- Liu, H., Zhu, N., Liu, S., et al.: One third optical frequency divider for dual-wavelength optical signals based on an optoelectronic oscillator. *Electron. Lett.* **56**(14), 727–729 (2020)
- Yao, X., Maleki, L.: Optoelectronic microwave oscillator. *J. Opt. Soc. Am. B* **13**(8), 1725–1735 (1996)
- Chen, Y., Zuo, P., Shi, T., et al.: Photonic-based reconfigurable microwave frequency divider using two cascaded dual-parallel Mach-Zehnder modulators. *Opt. Express* **28**(21), 30797–30809 (2020)