Charles Darwin University

Energy and exergy assessment with updated Reistad estimates

A case study in the transportation sector of Bangladesh

Chowdhury, Hemal; Chowdhury, Tamal; Rashedi, Ahmad; Banik, Sajal Chandra; Khanam, Taslima; Saidur, Rahman; Sait, Sadiq M.; Rosen, Marc A.

Published in:
Energy and Environmental Science

DOI:
[10.1002/ese3.896](https://doi.org/10.1002/ese3.896)

Published: 01/09/2021

Document Version
Publisher's PDF, also known as Version of record

[Link to publication](#)

Citation for published version (APA):

Chowdhury, H., Chowdhury, T., Rashedi, A., Banik, S. C., Khanam, T., Saidur, R., Sait, S. M., & Rosen, M. A. (2021). Energy and exergy assessment with updated Reistad estimates: A case study in the transportation sector of Bangladesh. *Energy and Environmental Science*, 9(9), 1349-1358. <https://doi.org/10.1002/ese3.896>

General rights

Copyright and moral rights for the publications made accessible in the public portal are retained by the authors and/or other copyright owners and it is a condition of accessing publications that users recognise and abide by the legal requirements associated with these rights.



- Users may download and print one copy of any publication from the public portal for the purpose of private study or research.
- You may not further distribute the material or use it for any profit-making activity or commercial gain
- You may freely distribute the URL identifying the publication in the public portal

Take down policy

If you believe that this document breaches copyright please contact us providing details, and we will remove access to the work immediately and investigate your claim.

RESEARCH ARTICLE

Energy and exergy assessment with updated Reistad estimates: A case study in the transportation sector of Bangladesh

Hemal Chowdhury¹  | Tamal Chowdhury²  | Ahmad Rashedi³  |
Sajal Chandra Banik¹ | Taslima Khanam³ | Rahman Saidur^{4,5} | Sadiq M. Sait⁶ |
Marc A. Rosen⁷

¹Department of Mechanical Engineering, Chittagong University of Engineering & Technology, Chattogram, Bangladesh

²Department of Electrical & Electronic Engineering, Chittagong University of Engineering & Technology, Chattogram, Bangladesh

³College of Engineering, IT & Environment, Charles Darwin University, Casuarina, Northern Territory, Australia

⁴Research Centre for Nano-Materials and Energy Technology (RCNMET), School of Science and Technology, Sunway University, Petaling Jaya, Malaysia

⁵Research Institute, King Fahd University of Petroleum & Minerals, Dhahran, Saudi Arabia

⁶Center for Communication and Information Technology, Research, King Fahd University of Petroleum & Minerals, Dhahran, Saudi Arabia

⁷Faculty of Engineering and Applied Science, University of Ontario Institute of Technology, Oshawa, Ontario, Canada

Correspondence

Ahmad Rashedi, College of Engineering, IT & Environment, Charles Darwin University, Ellengowan Drive, Casuarina, NT 0810, Australia.

Emails: mabrur.rashedi@cdu.edu.au; amma0002@ntu.edu.sg

Abstract

Transportation sector is one of the core parts of modern civilization. Proper utilization of energy and exergy in this sector is necessary to ensure energy loss and environmental sustainability. Increasing exergy efficiency will reduce carbon emissions from this sector. Since 1970, Reistad estimates have been widely used to determine the energy and exergy efficiencies of this sector. However, the modern transport sector has undergone significant changes in recent decades. Hence, it is necessary to apply new Reistad estimates in determining the energy and exergy efficiencies. This is the first study to apply updated Reistad estimates to explore the energy and exergy efficiencies in the transportation sector of Bangladesh based on the data from 2000 to 2017. The overall exergy efficiency is significantly lower than the energy efficiencies as it ranges from 27.7% to 30.0%. Efficiencies are lower as the maximum portion of input exergy is lost to the environment. The road subsector needs major improvements as it is responsible for major amount of exergy loss. A comparison is made between conventional and updated estimates which highlights that the updated estimates provide more accurate results. Thus, it is recommended to apply updated Reistad estimates in determining the energy and exergy efficiencies of the transport sector.

KEYWORDS

Bangladesh, energy, exergy, Reistad estimates, sustainability, transportation

1 | INTRODUCTION

Transportation is a significant sector of almost any society. Economic growth of a country is partially dependent on this,

as better transportation facilities provide more trade and increased productivity and support the distribution of products to different locations. Without a sound transportation system, economic development can come to a standstill. However,

This is an open access article under the terms of the Creative Commons Attribution License, which permits use, distribution and reproduction in any medium, provided the original work is properly cited.

© 2021 The Authors. *Energy Science & Engineering* published by the Society of Chemical Industry and John Wiley & Sons Ltd.

increasing the amount of transport can cause problems such as global warming. In today's world, the transportation sector is mainly fossil fuel-driven. Increasing amounts of transport add to the increasing use of fossil fuels. This contributes to increased air pollution, global warming, acid rain, etc.¹ Global warming not only affects human development but also poses a significant threat to people and their societies. Due to the heavy usage of fossil fuel in this sector, emissions are increasing rapidly. "Many countries all over the world have taken effective pro-active measures, such as the 'industrial energy tax,' carbon emission trading, enhanced management, and control over different sectors, etc aimed at meeting this challenge".²

"It is necessary to acquire an accurate quantitative assessment of the various waste gases emitted from the transportation sector in order to formulate appropriate strategies and policies".² Exergy analysis can be a powerful tool to accomplish this since it deals with both the quality and quantity of energy.^{3,4} Important information about energy systems and their improvement can be determined via exergy analysis.⁵⁻⁷ "Exergy analysis has been combined with economics to quantify the cost of the exergy destruction and losses, and the cost of artificial activities, thus optimizing various anthropic processes and improving the thermal-economic performances at each stage, thereby facilitating downstream decision-making".^{8,9}

Several researches have been conducted to analyze the exergy and resource efficiency of different processes and sectors. Zhang et al¹⁰ determined the exergy utilization in the Chinese agriculture sector. An exergy-based material flow analysis of Europe was done by Calvo et al.¹¹ Exergy-based indicators were applied to coastal lagoons by Austoni et al¹² and Tang et al.¹³ Fitzsimons et al¹⁴ applied exergy analysis to an Irish wastewater treatment plant, while Ansarinasab et al¹⁵ performed 3E analyses of a hydrogen liquefaction plant. Casas Ledón et al¹⁶ performed Exergy, Exergoeconomic, and Exergoenvironmental (EEA) of a horizontal flow constructed wetland for municipal wastewater treatment. EEA was applied to a wind power plant by Aghbashlo et al.¹⁷ Stylos et al¹⁸ evaluated the exergetic behavior of the hospitality industry. Zhang et al¹⁹ used an exergetic approach to understand the environmental impact of woody biomass. Şöhret et al²⁰ performed exergy analysis to determine the performance of a ramjet engine operating in hydrogen fuel. Ekici et al^{21,22} determined the exergetic parameters such as endogenous and exogenous exergy destruction of an experimental turbojet engine. Nielsen and Jørgensen²³ used exergy as a tool to understand the energy flow on the island of Samsø (Denmark), while Mosquim et al²⁴ undertook exergy analysis to evaluate the sectoral energy utilization of the Sao Paulo State (Brazil). Sustainability analysis of the rural residential sector of Bangladesh was done by Chowdhury et al.²⁵ Hossain et al²⁶ performed exergy analysis of different fuel-based power plants of Bangladesh and found that natural gas-operated power plants are less exergy efficient

and responsible for higher emissions. Chowdhury et al²⁷ performed exergetic sustainability analysis on Bangladesh agriculture sector and found that diesel machineries are responsible for lower sustainability.

Several studies have been conducted on transportation sectors to assess energy utilization efficiency. Federici et al²⁸ applied energy-based sustainability indicators to passenger cars in Italy. Saidur et al²⁹ determined the energetic and exergetic performance of the Malaysian transport sector. Table 1 lists selected transport sector studies.

From Table 1, it is evident that considerable analyses have been performed on the transportation sector. The majority of these are based on the estimated approach of Reistad.³⁰ Reistad³⁰ calculated the operating efficiencies of different transportation modes for US transportation modes in 1970. Modern transportation systems have undergone much improvement since then. With improved fuel economy and the introduction of new technologies such as advanced combustion and driving systems, and improved engine construction, operating efficiencies for most transportation modes have increased. Bligh and Ugursal³¹ updated the Reistad efficiency estimate for use in energetic and exergetic assessments of the transportation sector, considering the changes in various transportation modes. But after modification, no other study has applied updated Reistad efficiencies in analyzing the transport sector to our knowledge. This is the first analysis to use updated Reistad estimates to determine the energetic and exergetic performance of Bangladesh's transportation sector.

The transportation sector of Bangladesh is heavily dependent on fossil fuels to meet energy demand, and this dependence is expected to be maintained or rise in the coming years. Almost 100% of energy demand is fulfilled by fossil fuel. Transportation sector accounts for 12% energy consumption of the country (Sreda) and is responsible for 14.2% of CO₂ emissions in 2014. This value represents an increase of 3.4% in 2014 from 2013 (<https://knoema.com/atlas>). The total length of national roads was 21 365 km, and the total length of the rail system was 2877 km in 2015.³² Approximately 3.4 million registered vehicles use the roads, and it is expected to maintain a significant future growth. A study conducted by Richard Dietrich³³ identified several obstacles in the development of the transport sector. Majority of the registered vehicles are not modern, and these do not go scheduled maintenance. Higher cost of the modern automobile equipment also discourages people from utilizing them. The condition of public transport is worsening day by day as most of them are overloaded. Most of the fuels utilized are contaminated, and these pose difficulties in upgrading lower emission motors. Due to poor socio-economic conditions, most of the drivers are illiterate. They are not adequately trained and do not possess sufficient knowledge of green transportation. As a result, a considerable portion of the energy is lost from this sector. Bangladesh is exposed to environmental threats like

TABLE 1 Studies regarding the transportation sector

Authors	Country	Contributions
Dincer et al ⁴¹	Saudi Arabia	Determination of energy and exergy efficiencies from 1990 to 2001 and comparison with other countries
Byers et al ⁴²	UK	Framework for exergy analysis of future transport system from 2010 to 2050, with emphasis on electrification of passenger cars
Chen and Xi ⁴³	China	Determination of energy and exergy efficiencies from 1978 to 2002 and comparison with other countries
Zhang et al ⁴⁴	China	Determination of energy and exergy efficiencies from 1989 to 2002 and comparison with other countries
Dai et al ²	China	Extended exergy analysis for 2008 and determination of emission from the transport sector
Utlu and Hepbasli ⁴⁵	Turkey	Determination of energy and exergy efficiencies from 2000 to 2020, comparison with other countries and determination of improvement potential
Seckin et al ⁴⁶	Turkey	Extended exergy analysis for 2006 and determination of emissions
Konchou et al ⁴⁷	Cameroon	Determination of energy and exergy efficiencies from 2001 to 2010, comparison with other countries, and construction of exergy flow diagram
Amoo and Fagbenle ⁴⁸	Nigeria	Determination of energy and exergy efficiencies from 1988 to 2009 and comparison with other countries
Zarifi et al ⁴⁹	Iran	Determination of energy and exergy efficiencies from 1998 to 2009 and forecasted energy and exergy efficiencies from 2010 to 2035
Motasemi et al ⁵⁰	Canada	Determination of energy and exergy efficiencies and emissions from 1990 to 2035
Jaber et al ⁵¹	Jordan	Determination of energy and exergy efficiencies from 1985 to 2006 and comparison with other countries
Mitra and Gautam ⁵²	India	Determination of energy and exergy efficiencies from 2001 to 2016 and comparison with other countries
Koroneos and Nanaki ⁵³	Greece	Determination of energy and exergy efficiencies from 1980 to 2003 and comparison with other countries
Zhang and Wang ⁵⁴	China	Determination and projection of exergy consumption and efficiencies in 2006 and 2030

global warming. Due to global warming, the Bay of Bengal level may rise.³² As a result, many coastal areas may become submerged by the sea. Therefore, proper planning is needed in the transportation sector for high efficiency and less environmental impact. Energy planners of Bangladesh and other countries can identify the real energy scenario of this sector and take measures to reduce energy and exergy losses by using updated Reistad estimates.

2 | METHODOLOGY

2.1 | Components of exergy analysis

Some fundamental relations used for exergy analysis are taken from Rosen.³⁴

2.1.1 | Exergy of work

“Exergy associated with shaft work (W) is equal to the energy” and can be written as²⁹:

$$E^W = W \quad (1)$$

2.1.2 | Exergy of fuel

At ambient temperature and pressure, the chemical exergy and specific exergy of fuel are approximately the same and written as follows²⁹:

$$\epsilon_{ff} = \gamma_{ff} H_{ff} \quad (2)$$

where H = Higher heating value (kJ/kg), γ = Exergy grade function.

The exergy grade functions for selected fuels are presented in Table 2.

2.2 | Energy and exergy efficiencies for different processes

“The energy efficiency is the ratio of energy in products and energy input whereas exergy efficiency is the ratio of exergy in products and exergy input”.²⁹ The energy and exergy efficiencies can be expressed respectively for most processes as³⁵:

$$\text{Energy efficiency, } \eta = \frac{\text{Output energy}}{\text{Total energy input}} \quad (3)$$

$$\text{Exergy efficiency, } \varphi = \frac{\text{Output exergy}}{\text{Total exergy input}} \quad (4)$$

2.3 | Improvement potential

Van Gool³⁶ stated that “minimizing the irreversibilities of a process can lead to obtaining maximum exergy efficiency.” The improvement potential (IP) can be expressed as:

$$\text{IP} = (1 - \varphi) (\text{Exergy input} - \text{Exergy Output}) \quad (5)$$

Since, $\varphi = \frac{\text{Exergy output}}{\text{Exergy input}}$, the IP is expressed as:

$$\text{IP} = (1 - \varphi)^2 \times \text{Exergy Input} \quad (6)$$

TABLE 2 Typical values of H_{ff} , ϵ_{ff} , γ_{ff} for various fuels used in the current study^{29,38}

Fuel	H_{ff} (kJ/kg)	Chemical exergy (kJ/kg)	γ_{ff}
Gasoline	47 849	47 394	0.99
Fuel oil	47 405	47 101	0.99
Natural gas	55 448	51 702	0.93
Kerosene	46 117	45 897	0.99
Diesel	39 500	42 265	1.07

2.4 | Data source

The necessary data on fuel utilization are taken from the United Nations energy database for Bangladesh (<https://knoema.com>) and the International Energy Agency³⁷ (www.iea.org). Diesel, natural gas, gasoline, fuel oil, and jet fuel are mainly used as fuels in the transportation sector. Data on fuel consumption by various transportation modes are presented in Table 3.

The exergy consumption by each mode is shown in Figure 1. From Figure 1, it is seen that the quantity of exergy consumption is increasing every year. The total exergy consumption was 41.9 PJ in 2000, whereas it was 157.7 PJ in 2017. The road mode consumed more exergy than all other modes. Energy consumption in this subsector is expected to rise in the coming years due to increasing vehicles. Natural gas-fueled vehicles were introduced in 2002 and since then have contributed much to energy consumption. Diesel and natural gas will provide most of the exergy in the future. The share of gasoline will decrease as the most consumers prefer using natural gas in their automobiles due to the higher price of gasoline. The naval mode consumed a lower amount of exergy as the number of mechanized vehicles is lower. Traditional boats and dinghies (small boats) are mostly used by local passengers.

2.5 | Steps and procedure

The transportation sector of Bangladesh consists of four sub-sectors: road, rail, air, and water. The operating efficiencies

Year	Road			Rail	Naval	Air	Total
	Diesel	Petrol	Natural gas	Diesel	Fuel oil	Aviation jet fuel	
2000	18.3	11.3	-	4.4	1.51	4.98	40.5
2001	24.7	11.1	-	5.9	1.51	8.21	51.4
2002	25.4	10.8	-	6.1	1.51	8.50	52.2
2003	24.9	12.5	0.24	6.0	2.26	9.59	55.5
2004	23.5	11.3	2.0	7.45	2.39	9.50	56.2
2005	31.5	12.1	3.7	6.45	2.51	10.63	67.0
2006	31.8	12.9	7.3	6.91	2.68	9.96	71.5
2007	31.8	9.0	13.0	6.71	2.85	9.46	72.9
2008	32.4	9.0	24.9	6.82	3.06	11.6	87.8
2009	46.0	8.1	33.8	6.74	3.22	10.6	108.5
2010	51.9	8.9	43.2	6.91	3.39	12.0	126.4
2011	47.6	10.0	42.3	11.1	3.60	14.1	128.6
2012	47.5	11.0	42.4	11.2	3.85	13.1	129.1
2013	43.5	11.6	42.5	10.3	4.10	13.3	125.3
2014	47.5	12.3	44.2	11.2	4.19	13.5	132.9
2015	49.7	12.2	47.4	11.8	4.48	14.2	139.7
2016	58.66	11.85	51.35	12.48	4.81	14.53	153.68
2017	52.88	17.5	51.9	13.86	5.10	15.80	157.04

TABLE 3 Energy consumption (in PJ) breakdown by transportation subsector from 2000 to 2017

FIGURE 1 Exergy usage by different modes of Bangladesh transportation sector for 2000-2017

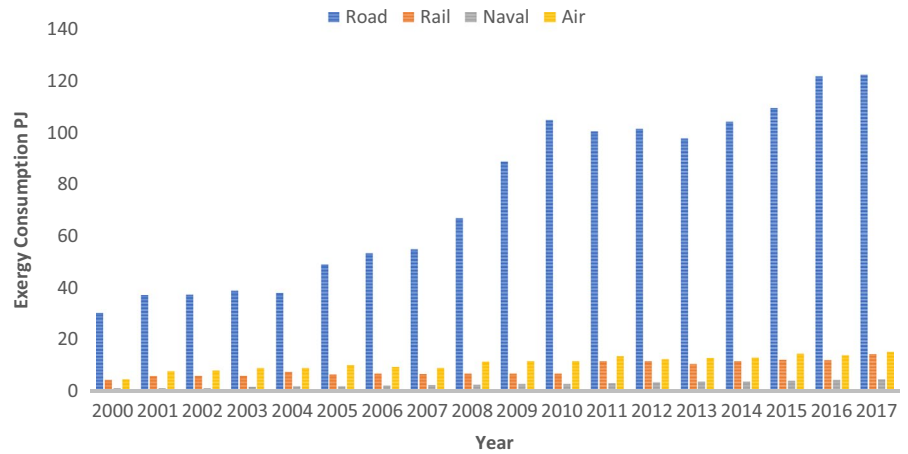

TABLE 4 Reistad and Updated Reistad efficiencies for various transportation modes

Mode	Reistad estimate (estimated operating efficiency %)	Updated Reistad estimate (estimated operating efficiency %)
Car	15	24
Truck	25	28
Aircraft	28	46
Rail	28	33
Naval	28	32

of the transportation subsectors were calculated for the vehicles used in 1970 by Reistad.³⁰ However, due to modernizations of vehicles, the operating efficiencies of the vehicles have increased. Therefore, the application of these efficiency values will cause inaccuracy in assessing the energy utilization of this sector. Taking the change into consideration, Bligh and Ugursal³¹ updated the operating efficiencies. The current analysis presents a comparison of obtained results after applying both Reistad and updated Reistad efficiencies. But the focus is on the updated Reistad efficiencies as they take into account developments in fuel economy and operating efficiencies of the transportation modes. Table 4 shows the Reistad and updated Reistad operating efficiencies.

For determining both efficiencies, the procedure adopted by Saidur et al²⁹ and Dincer et al³⁸ is followed. “First, the weighting factor is determined, where the weighting factor is defined as the ratio of energy input for a mode to the sector's total energy input. Multiplying the weighing factor by the individual mode's energy efficiency permits the weighted mean energy efficiency for each mode to be found. Then summing the weighted mean energy efficiency of each transport mode, the weighted mean overall energy efficiency of the transport sector can be evaluated for a particular year. The overall weighted mean energy efficiency can be determined as follows”²⁹:

$$F_{\eta o} = \sum_{ij} \eta_i \times Tr_{i,j} \tag{7}$$

where, $F_{\eta o}$ = Overall weighted mean energy efficiency, $Tr_{i,j}$ = Energy fraction of the j th energy form used by the i th transportation mode.

For exergy, a similar procedure is followed.²⁹ “By multiplying the weighting factor by the energy efficiency of that mode divided by exergy grade function of the fuel, the weighted mean exergy efficiency for each mode of the transport is calculated. By summing the weighted mean exergy efficiency of each mode, the weighted mean overall exergy efficiency of the transport sector for a particular year can be calculated. The overall weighted mean exergy efficiency can be determined”, following, Saidur et al²⁹ as:

$$F_{\varphi o} = \sum_{i,j} \frac{\eta_i}{\gamma_j} \times Tr_{i,j} \tag{8}$$

where, $F_{\varphi o}$ = Overall weighted mean exergy efficiency.

3 | RESULTS AND DISCUSSION

3.1 | Overall energy and exergy efficiencies

In this section, the overall energy and exergy efficiencies of the transportation sector after applying both conventional Reistad and updated Reistad efficiencies are presented. Table 5 lists the energy and exergy efficiencies of this sector.

TABLE 5 Overall energy and exergy efficiencies for the transportation sector from 2000 to 2017

Year	Overall energy efficiency using updated Reistad efficiencies (%)	Overall exergy efficiency using updated Reistad efficiencies (%)	Overall energy efficiency using Reistad efficiencies (%)	Overall exergy efficiency using Reistad efficiencies (%)
2000	29.7	28.8	23.1	22.8
2001	30.7	29.7	23.5	22.7
2002	31.0	30.0	23.5	22.6
2003	30.9	30.1	23.4	22.7
2004	30.9	30.1	23.5	22.8
2005	30.9	30.0	23.3	22.6
2006	30.2	29.5	23.2	22.6
2007	29.7	29.2	23.0	22.6
2008	29.4	29.2	23.0	22.9
2009	28.0	27.7	22.7	22.6
2010	28.4	28.2	22.7	22.6
2011	28.7	28.5	23.0	22.9
2012	29.0	28.8	22.9	22.8
2013	28.8	28.6	22.9	22.9
2014	28.4	28.2	22.9	22.8
2015	28.4	28.0	22.9	22.8
2016	28.02	26.63	21.96	21.86
2017	28.07	27.93	22.02	21.97

It is evident that both energy and exergy efficiencies are higher after applying the updated Reistad efficiencies. The energy efficiencies vary from 28.0% to 31.0%, while exergy efficiencies vary from 27.7% to 30.0%. Applying old operating efficiencies, the transportation sector energy efficiencies vary between 22.7% and 23.5% while the exergy efficiencies vary between 22.6% and 22.9%. It is seen that the application of old operating efficiencies does not allow the determination of the true energy and exergy utilization scenario of the transportation sector. Therefore, it is essential to use the new operating efficiencies.

Table 5 shows that the exergy efficiency (updated) exhibits a very slight decreasing trend for most years. With an increased number of vehicles on the road, exergy losses from the vehicles also increase. This is especially true for older vehicles, which consume a considerable portion of the input exergy and are less efficient. Other factors such as lack of investment in this sector due to political instability, lack of modern automobile equipment, poor conditions of roads, and lack of proper transportation policy also contribute significantly to the energy and exergy losses and reduced efficiencies over time. Table 5 also shows that the road mode is more exergy efficient than others and that the exergy efficiency for this mode is slightly lower than the energy efficiency. So, exergy analysis should be the main tool in designing a country or society's transportation policy, not energy analysis, which does not consider irreversibilities.

3.2 | Energy and exergy loss

In this section, energy and exergy loss diagrams are considered to illustrate and clarify the losses. Energy and exergy flow diagrams for 2015 are presented in Figures 2 and 3, respectively. From Figure 2, it is evident that the road mode utilized the highest amount of energy, mostly from diesel and natural gas. In 2017, about 15.80 PJ of Diesel energy was transformed into product and 40.8 PJ was lost. The energy loss from natural gas is high and it reached 34.8 PJ in 2017. About 28.1% of the consumed natural gas energy was transformed into the product and the rest was lost to the atmosphere. The exergy loss from different fuels is given in Figure 3. The road subsector utilized more exergy than other subsectors and the majority of it from diesel and natural gas. Exergy loss from diesel vehicles was the highest at 43.6 petajoules and about 16.9 petajoules were converted into product. The losses in the road subsector are large mainly because of the prevalence of vehicular traffic. Many of these vehicles are old and use old automobile equipment and are not properly maintained. Contributing to this loss is the fact that many vehicles use of faulty combustion systems. Also, the roads are narrow and zigzag, leading to much stop-and-go driving, and most of the vehicles are overloaded. Furthermore, drivers often are not adequately trained and are unaware of issues surrounding the energy-efficient usages of vehicles.

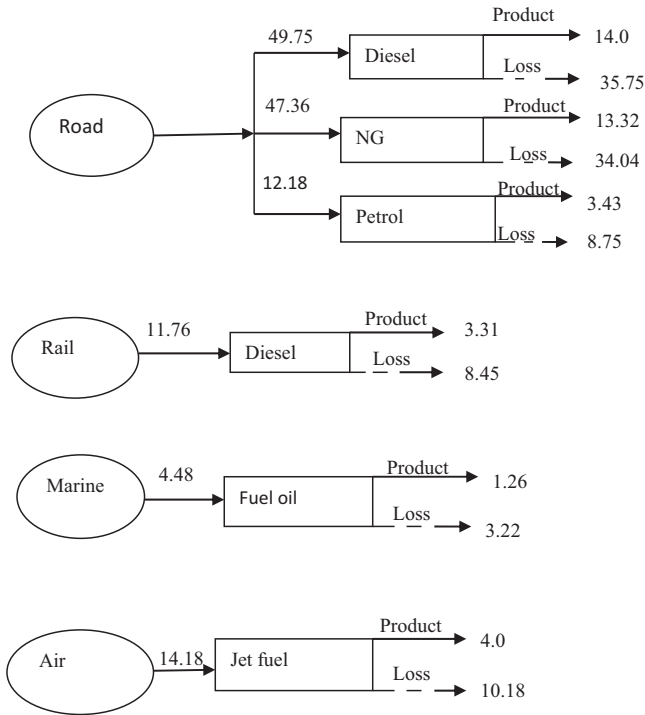

FIGURE 2 Energy flow diagram of Bangladesh transportation sector for the year 2015

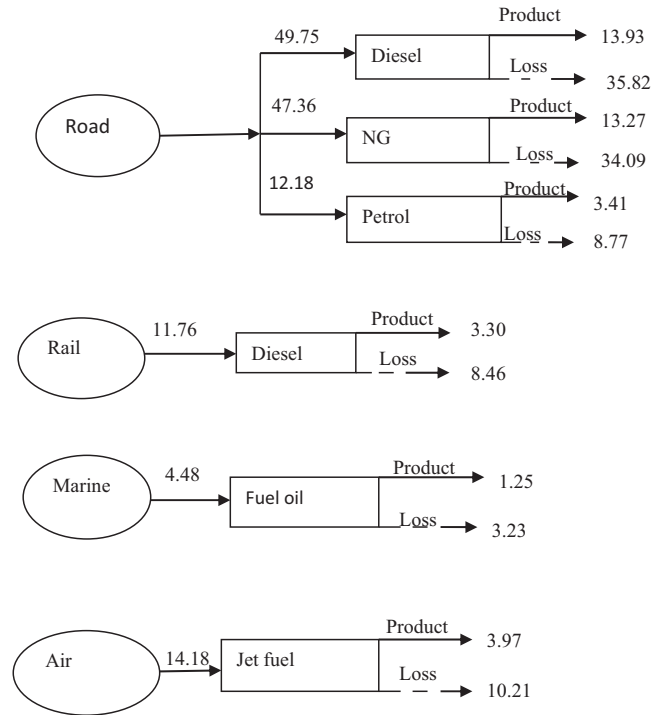

FIGURE 3 Exergy flow diagram of Bangladesh transportation sector for the year 2015

Other factors contributing to this loss include improper modal mix, non-integrated transportation system, lack of policy reform regarding urban and regional transportation policy, and heavy dependence on fossil fuels.

3.3 | Comparison with other countries

In this section, the transportation sector of Bangladesh is compared with selected countries with respect to exergy efficiency (with updated Reistad efficiencies). From Table 6, it is evident that Bangladesh's transportation sector is more exergy efficient than those of the USA, the UK, Malaysia, Jordan, Greece, Saudi Arabia, Sweden, Canada, and Turkey. This is mainly due to the dissimilar structure of transportation modes, the types of fuel used, the amount of fuel consumption, the density of vehicles on the road, and government policies regarding the transportation sector. The purpose of this comparison is to highlight the discrepancies in obtained results among previous researches and the current one. Previous studies used conventional estimates without considering the development in transportation modes. Hence, the obtained results did not truly reflect the energy and exergy utilization efficiencies of the transport sectors. This analysis applies the updated estimates, and hence, the obtained efficiencies are up to date. Hence, it is necessary to apply updated estimates rather than conventional ones to determine energy and exergy utilization in this sector.

TABLE 6 Exergy efficiencies of the transportation sector of selected countries

Country	Year analyzed	Exergy efficiency (%)	Reference
Bangladesh	2000-2015	27.7-30.0	Current study
USA	1970	20	Ertesvåg ⁵⁵
UK	1997	19	Utlu and Hepbasli ⁴⁵
Malaysia	1995-2003	22.8-22.4	Saidur et al ²⁹
Jordan	1985-2006	22.8	Jaber et al ⁵¹
Greece	1980-2003	20.9-21.4	Koroneos and Nanaki ⁵³
Turkey	2000	23.6	Utlu and Hepbasli ⁴⁵
Saudi Arabia	1990-2001	21.4-21.8	Dincer et al ⁴¹
Canada	1986	23	Ertesvåg ⁵⁵
Sweden	1980	10	Ertesvåg ⁵⁵

3.4 | Improvement potential of transportation sector

This subsection presents the improvement potential of the transport sector of Bangladesh. From Figure 4, it is observed that the road mode exhibits a greater improvement potential than other modes. The exergy consumption in the road mode is higher than for any other mode and its irreversibility is

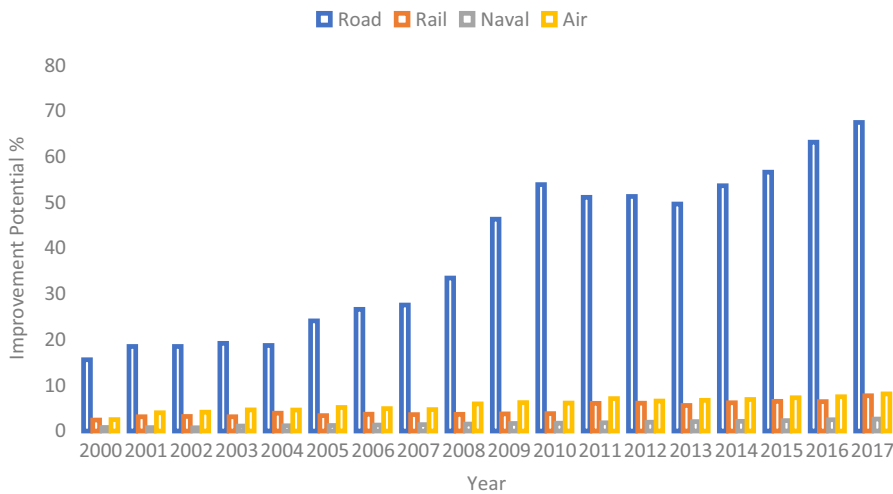

FIGURE 4 Improvement potential of different modes of Bangladesh transportation sector from 2000 to 2017

greater. The improvement potential increased from 15.6% in 2000 to 67.5% in 2017. The improvement potentials of rail and air modes are close, partly because their exergy usages are close. The improvement potential of the rail mode increased from 2.4% in 2000 to 7.71% in 2017, while the improvement potential of air mode increased over the same time frame from 2.5% to 8.13%. Note that the improvement potential of individual subsectors and the exergy consumption by each subsector exhibit similar trends, mainly due to the increasing exergy loss associated with increasing exergy consumption and efficiencies being close to each other.

4 | CONCLUSIONS

The current analysis focuses on implementing updated Reistad estimates to determine the energy and exergy efficiency of the Bangladesh transport sector. It is found that updated estimates provide more accurate results while determining sectoral exergy efficiencies. From this analysis, it is found that Bangladesh's transportation sector is only 30% exergy efficient, and a considerable portion of exergy can be conserved by implementing green technologies. To afford widespread use of green technology, investment from both the public and private sectors is necessary. The government should provide funding and tax incentives on R&D programs for promoting green transportation. Subsidiary should be provided on cleans fuel to make them more lucrative. The potential of non-motorized vehicles such as bicycles should be explored. Promoting bicycles instead of electric autorickshaw, taxi, and motor bikes would also result in economic and environmental benefits and mitigate the congestion problem.³⁹ Considerable portion of diesel fuel is lost during locomotives idling time as the engine is kept running to avoid the long duration required to restart the engine. Utilization of Auxiliary power units (APU) will allow the stoppage of the main engine during idle time. APU is successfully applied throughout the world in train engines, and the

application of this technology will result in cost-saving and pollution reduction. The potential of alternative fuels like biodiesel and bioethanol from agriculture and biowaste should be investigated in greater detail in the future. Utilization of E5 (blend of 5% Ethanol and 95% diesel) in the transport sector will result in an annual reduction of 7 and 7.4 Kt of petrol and octane.⁴⁰ Promoting knowledge among the public on the environment-exergy nexus can drive measures to reduce the emission from the transportation sector. Measures such as proper choosing of vehicles, removal of old vehicles, schedule maintenance of vehicles, using latest tires instead of old tires, selection of environment-friendly fuels, arranging training programs for drivers, and implementation of energy and environmentally supportive policies regarding transportation will help upgrade the current energy scenario of Bangladesh.

ACKNOWLEDGMENT

The technical help and resources provided by the Chittagong University of Engineering and Technology (Department of Mechanical Engineering) and Charles Darwin University are greatly acknowledged.

Nomenclature

3E	Exergy, Exergoeconomic, and Exergoenvironmental
E^W	Exergy flow (kJ)
EEF	Environmental Effect Factor
EEA	Extended Exergy Accounting
$F_{\eta o}$	Overall weighted mean energy efficiency
$F_{\varphi o}$	Overall weighted mean exergy efficiency
H	Higher heating value (kJ/kg)
$Tr_{i,j}$	Energy fraction of the j th energy form used by the i th transportation mode
W	Shaft work (kJ)

Greek symbols

η	Energy efficiency
φ	Exergy efficiency

γ	Exergy grade function
ε	Specific exergy (kJ/kg)

Subscripts

<i>ex</i>	Output condition
<i>ff</i>	Fossil fuel
<i>in</i>	Input condition
<i>o</i>	Overall system

ORCID

Hemal Chowdhury  <https://orcid.org/0000-0001-6291-4236>

Tamal Chowdhury  <https://orcid.org/0000-0001-8975-7752>

Ahmad Rashedi  <https://orcid.org/0000-0001-5791-8144>

REFERENCES

- Rashedi A, Khanam T. Life cycle assessment of most widely adopted solar photovoltaic energy technologies by mid-point and end-point indicators of ReCiPe method. *Environ Sci Pollut Res.* 2020;2020(27):29075-29090.
- Dai J, Chen B, Sciubba E. Extended exergy based ecological accounting for the transportation sector in China. *Renew Sustain Energy Rev.* 2014;32:229-237. <https://doi.org/10.1016/j.rser.2014.01.001>
- Ahamed JU, Saidur R, Masjuki HH, Mekhilef S, Ali MB, Furqon MH. An application of energy and exergy analysis in agricultural sector of Malaysia. *Energy Pol.* 2011;39:7922-7929. <https://doi.org/10.1016/j.enpol.2011.09.045>
- Ekici S. Thermodynamic mapping of A321-200 in terms of performance parameters, sustainability indicators and thermo-ecological performance at various flight phases. *Energy.* 2020;202:117692. <https://doi.org/10.1016/j.energy.2020.117692>
- Chowdhury H, Chowdhury T, Hossain N, et al. Exergetic sustainability analysis of industrial furnace: a case study. *Environ Sci Pollut Res.* 2020;28(10):12881-12888. <https://doi.org/10.1007/s11356-020-11280-3>
- Kanoğlu M, Kazim Işik S, Abuşoğlu A. Performance characteristics of a Diesel engine power plant. *Energy Convers Manage.* 2005;46:1692-1702. <https://doi.org/10.1016/j.enconman.2004.10.005>
- Rashedi A, Khanam T, Jonkman M. On reduced consumption of fossil fuels in 2020 and its consequences in global environment and exergy demand. *Energies.* 2020;2020(13):6048.
- Ekici S, Sohret Y, Coban K, Altuntas O, Karakoc TH. Performance evaluation of an experimental turbojet engine. *Int J Turbo Jet-Eng.* 2016;34(4):365-375. <https://doi.org/10.1515/tjj-2016-0016>
- Tsatsaronis G. Thermoeconomic analysis and optimization of energy systems. *Progr Energy Combust Sci.* 1993;19(3):227-257.
- Zhang B, Jin P, Qiao H, Hayat T, Alsaedi A, Ahmad B. Exergy analysis of Chinese agriculture. *Ecol Ind.* 2017;105:279-291. <https://doi.org/10.1016/j.ecolind.2017.08.054>
- Calvo G, Valero A, Valero A. Material flow analysis for Europe: an exergoecological approach. *Ecol Ind.* 2016;60:603-610. <https://doi.org/10.1016/j.ecolind.2015.08.005>
- Austoni M, Giordani G, Viaroli P, Zaldívar JM. Application of specific exergy to macrophytes as an integrated index of environmental quality for coastal lagoons. *Ecol Ind.* 2007;7(2):229-238. <https://doi.org/10.1016/j.ecolind.2006.01.001>
- Tang D, Zou X, Liu X, et al. Integrated ecosystem health assessment based on eco-exergy theory: a case study of the Jiangsu coastal area. *Ecol Ind.* 2015;48:107-119. <https://doi.org/10.1016/j.ecolind.2014.07.027>
- Fitzsimons L, Horrigan M, McNamara G, et al. Assessing the thermodynamic performance of Irish municipal wastewater treatment plants using exergy analysis: a potential benchmarking approach. *J Clean Prod.* 2016;131:387-398. <https://doi.org/10.1016/j.jclepro.2016.05.016>
- Ansarinasab H, Mehrpooya M, Sadeghzadeh M. An exergy-based investigation on hydrogen liquefaction plant - exergy, exergoeconomic, and exergoenvironmental analyses. *J Clean Prod.* 2018;210:530-541. <https://doi.org/10.1016/j.jclepro.2018.11.090>
- Casas Ledón Y, Rivas A, López D, Vidal G. Life-cycle greenhouse gas emissions assessment and extended exergy accounting of a horizontal-flow constructed wetland for municipal wastewater treatment: a case study in Chile. *Ecol Ind.* 2017;74:130-139. <https://doi.org/10.1016/j.ecolind.2016.11.014>
- Aghbashlo M, Tabatabaei M, Hosseini SSB, Dashti B, Mojarab Soufiyan M. Performance assessment of a wind power plant using standard exergy and extended exergy accounting (EEA) approaches. *J Clean Prod.* 2018;171:127-136. <https://doi.org/10.1016/j.jclepro.2017.09.263>
- Stylos N, Koroneos C, Roset J, González-Sánchez C, Xydis G, Muñoz FS. Exergy as an indicator for enhancing evaluation of environmental management performance in the hospitality industry. *J Clean Prod.* 2018;198:1503-1514. <https://doi.org/10.1016/j.jclepro.2018.07.107>
- Zhang Y, Gao X, Li B, Li H, Zhao W. Assessing the potential environmental impact of woody biomass using quantitative universal exergy. *J Clean Prod.* 2018;176:693-703. <https://doi.org/10.1016/j.jclepro.2017.12.159>
- Şöhret Y, Ekici S, Karakoc TH. Using exergy for performance evaluation of a conceptual ramjet engine burning hydrogen fuel. *Int J Hydrogen Energy.* 2018;43(23):10842-10847. <https://doi.org/10.1016/j.ijhydene.2017.12.060>
- Ekici S, Altuntas O, Açıkkalp E, Sogut MZ, Karakoc TH. Assessment of thermodynamic performance and exergetic sustainability of turboprop engine using mixture of kerosene and methanol. *Int J Exergy.* 2016;19(3):295. <https://doi.org/10.1504/ijex.2016.075666>
- Ekici S, Orhan İ, Şöhret Y, Altuntaş Ö, Karakoç TH. Calculating endogenous and exogenous exergy destruction for an experimental turbojet engine. *Int J Turbo Jet-Eng.* 2019. <https://doi.org/10.1515/tjj-2019-0005>
- Nielsen SN, Jørgensen SE. Sustainability analysis of a society based on exergy studies - a case study of the island of Samsø (Denmark). *J Clean Prod.* 2015;96:12-29. <https://doi.org/10.1016/j.jclepro.2014.08.035>
- Mosquim RF, de Oliveira Junior S, Keutenedjian Mady CE. Modelling the exergy behavior of São Paulo State in Brazil. *J Clean Prod.* 2018;197:643-655. <https://doi.org/10.1016/j.jclepro.2018.06.235>
- Chowdhury T, Chowdhury H, Chowdhury P, et al. A case study to application of exergy-based indicators to address the sustainability of Bangladesh residential sector. *Sustain Energy Technol Assess.* 2020;37:100615. <https://doi.org/10.1016/j.seta.2019.100615>
- Hossain S, Chowdhury H, Chowdhury T, et al. Energy, exergy and sustainability analyses of Bangladesh's power generation

- sector. *Energy Reports*. 2020;6:868-878. <https://doi.org/10.1016/j.egy.2020.04.010>
27. Chowdhury T, Chowdhury H, Ahmed A, et al. Energy, exergy, and sustainability analyses of the agricultural sector in Bangladesh. *Sustainability*. 2020;12(11):4447. <https://doi.org/10.3390/su12114447>
 28. Federici M, Ulgiati S, Verdesca D, Basosi R. Efficiency and sustainability indicators for passenger and commodities transportation systems. *Ecol Ind*. 2003;3(3):155-169. [https://doi.org/10.1016/s1470-160x\(03\)00040-2](https://doi.org/10.1016/s1470-160x(03)00040-2)
 29. Saidur R, Sattar MA, Masjuki HH, Ahmed S, Hashim U. An estimation of the energy and exergy efficiencies for the energy resources consumption in the transportation sector in Malaysia. *Energy Pol*. 2007;35:4018-4026. <https://doi.org/10.1016/j.enpol.2007.02.008>
 30. Reistad GM. Available energy conversion and utilization in the United States. *J Eng Power*. 1975;97(3):429-434. <https://doi.org/10.1115/1.3446026>
 31. Bligh DC, Ugursal VI. Exergy efficiency factors for transportation: updated Reistad estimates. *Int J Exergy*. 2013;12(2):273-277.
 32. Statistical Yearbook of Bangladesh. *Bangladesh Bureau of Statistics: Bangladesh*. Statistics and Information Division, Ministry of Planning, Government of Peoples Republic of Bangladesh; 2015.
 33. Dietrich R. *Country Scoping of Research Priorities on Low-carbon Transport in Bangladesh*; 2020. www.gov.uk.com. Accessed: 27.1.2021.
 34. Rosen MA. Evaluation of energy utilization efficiency in Canada using energy and exergy analyses. *Energy*. 1992;17:339-350. [https://doi.org/10.1016/0360-5442\(92\)90109-D](https://doi.org/10.1016/0360-5442(92)90109-D)
 35. Rosen MA, Dincer I. Sectoral energy and exergy modeling of Turkey. *J Energy Res Technol*. 1997;119(3):153-158. <https://doi.org/10.1115/1.2794990>
 36. Van Gool W. Energy policy: fairy tales and factualities. In: Soares ODD, Martins da Cruz A, Costa Pereira G, Soares IMRT, Reis AJPS, eds. *Innovation and Technology-Strategies and Policies*. Dordrecht: Kluwer Academic Publisher; 1997:93-105.
 37. *International Energy Agency, (Bangladesh)*. <http://www.iea.org/countries/non-membercountries/bangladesh>. Accessed: 8/9/2019.
 38. Dincer I, Hussain MM, Al-Zaharnah I. Analysis of sectoral energy and exergy use of Saudi Arabia. *Int J Energy Res*. 2004;28:205-243. <https://doi.org/10.1002/er.962>
 39. Küster F, Blondel B. *Calculating the Economic Benefits of Cycling in EU-27*. Report of European Cyclist Federation (ECF); 2013. www.ecf.com. Accessed: 27/1/2021.
 40. Miskat MI, Ahmed A, Chowdhury H, et al. Assessing the theoretical prospects of bioethanol production as a biofuel from agricultural residues in Bangladesh: a review. *Sustainability*. 2020;12:8583. <https://doi.org/10.3390/su12208583>
 41. Dincer I, Hussain MM, Al-Zaharnah I. Energy and exergy utilization in transportation sector of Saudi Arabia. *Appl Therm Eng*. 2004;24:525-538. <https://doi.org/10.1016/j.appltherma.2003.10.011>
 42. Byers EA, Gasparatos A, Serrenho AC. A framework for the exergy analysis of future transport pathways: application for the United Kingdom transport system 2010–2050. *Energy*. 2015;88:849-862. <https://doi.org/10.1016/j.energy.2015.07.021>
 43. Ji X, Chen GQ. Exergy analysis of energy utilization in the transportation sector in China. *Energy Pol*. 2006;34:1709-1719. <https://doi.org/10.1016/j.enpol.2005.01.012>
 44. Zhang M, Li G, Mu HL, Ning YD. Energy and exergy efficiencies in the Chinese transportation sector, 1980–2009. *Energy*. 2011;36:770-776. <https://doi.org/10.1016/j.energy.2010.12.044>
 45. Utlu Z, Hepbasli A. Assessment of the energy utilization efficiency in the Turkish transportation sector between 2000 and 2020 using energy and exergy analysis method. *Energy Pol*. 2006;34:1611-1618. <https://doi.org/10.1016/j.enpol.2004.12.011>
 46. Seckin C, Sciubba E, Bayulken AR. Extended exergy analysis of Turkish transportation sector. *J Clean Prod*. 2013;47:422-436. <https://doi.org/10.1016/j.jclepro.2012.07.008>
 47. Talla Konchou FA, Aloyem Kaze CV, Tchinda R. An application of energy and exergy analysis at the transportation sector of Cameroon. *Int J Exergy*. 2015;18(2):129-141.
 48. Amoo LM, Fagbenle RL. A thermodynamic performance analysis of the transport sector of Nigeria. *Int J Exergy*. 2014;14:441-458. <https://doi.org/10.1504/IJEX.2014.062912>
 49. Zarifi F, Mahlia TMI, Motasemi F, Shekarchian M, Moghavvemi M. Current and future energy and exergy efficiencies in the Iran's transportation sector. *Energy Convers Manage*. 2013;74:24-34. <https://doi.org/10.1016/j.enconman.2013.04.041>
 50. Motasemi F, Afzal MT, Salema AA, Moghavvemi M, Shekarchian M, Zarifi F. Energy and exergy utilization efficiencies and emission performance of Canadian transportation sector, 1990–2035. *Energy*. 2014;64:355-366. <https://doi.org/10.1016/j.energy.2013.09.064>
 51. Jaber JO, Al-Ghandoor A, Sawalha SA. Energy analysis and exergy utilization in the transportation sector of Jordan. *Energy Pol*. 2008;36:2985-2990. <https://doi.org/10.1016/j.enpol.2008.04.004>
 52. Mitra S, Gautam D. An application of energy and exergy analysis of transport sector of India. *Int Open Access J Modern Eng Res (IJMER)*. 2014;4(6):7-15.
 53. Koroneos CJ, Nanaki EA. Energy and exergy utilization assessment of the Greek transport sector. *Resour Conserv Recycl*. 2008;52:700-706. <https://doi.org/10.1016/j.resconrec.2007.09.006>
 54. Zhang M, Wang W. Analysis of exergy utilization in the Chinese transportation sector. *Int J Green Energy*. 2011;8(3):349-360. <https://doi.org/10.1080/15435075.2011.557846>
 55. Ertesvåg IS. Society exergy analysis: a comparison of different societies. *Energy*. 2001;26:253-270. [https://doi.org/10.1016/S0360-5442\(00\)00070-0](https://doi.org/10.1016/S0360-5442(00)00070-0)

How to cite this article: Chowdhury H, Chowdhury T, Rashedi A, et al. Energy and exergy assessment with updated Reistad estimates: A case study in the transportation sector of Bangladesh. *Energy Sci Eng*. 2021;9:1349–1358. <https://doi.org/10.1002/ese3.896>